

**IQ500, Heat pump tumble dryer, 9 kg
WQ45G2D9GB**



A++



Outstanding laundry performance with A++, selfCleaning condenser and autoDry for gentle and even drying of your garments.

- ✓ selfCleaning condenser – Removes lint, saving you time and effort.
- ✓ Energy Efficiency Class A++ – Dries very efficiently
- ✓ Half load – Use the right programme to estimate the length of time needed for smaller loads in the dryer.
- ✓ speedPack – Save time with our fast and highly efficient dryers.
- ✓ autoDry – Gentle and precise drying that protects your clothes.

Features

Technical Data

Built-in / Free-standing: Freestanding
 Removable top: No
 Door hinge: Right
 Length electrical supply cord: 179.5 cm
 Height of removable worktop: 0 mm
 Dimensions: 842 x 598 x 613 mm
 Weight: 53.8 kg
 Fluorinated greenhouse gases: No
 Type of refrigerant: R290
 Hermetically sealed equipment: Yes
 The quantity expressed in CO2 equivalent: 0.000 t
 EAN code: 4242003912140
 Connection Rating: 800 W
 Fuse protection: 10 A
 Nominal power: 220-240 V
 Frequency: 50 Hz
 Capacity: 9.0 kg
 Energy efficiency rating: A++
 Energy consumption electric dryer, full load - NEW (2010/30/EC):
 2.05 kWh
 Standard cotton programme time at full load: 176 min
 Energy consumption electric dryer, partial load - NEW (2010/30/EC):
 1.25 kWh
 Standard cotton programme time at partial load: 121 min
 Weighted annual energy consumption, electric dryer - NEW
 (2010/30/EC): 258.0 kWh/annum
 Weighted programme time: 145 min
 Average condensation efficiency full load (%): 86 %
 Average condensation efficiency partial load (%): 86 %
 Weighted condensation efficiency (%): 86 %



Optional accessories

WZ20600	Wool in basket - accessory
WZ27400	Stacking kit with pull-out shelf
WZ27410	Stacking kit
WZDP20D	Platform with pull-out, dryer, cubic

IQ500, Heat pump tumble dryer, 9 kg
WQ45G2D9GB

Features	
<ul style="list-style-type: none"> • Extraklasse on panel <p>Performance</p> <ul style="list-style-type: none"> • Energy Efficiency Class¹: A++ • Energy²: 258 kWh • Capacity: 1 - 9 kg • Programme time³: 176 min • Noise level: 64 dB (A) re 1 pW • Condensation efficiency class⁴: B • Condensation efficiency⁵: 86 % <p>Programmes/functions</p> <ul style="list-style-type: none"> • Touch control buttons: Iron dry, Cupboard dry, Cupboard dry+, end time delay, less ironing, low heat, buzzer, Start / Reload / Pause, 24 h end time delay • Standard programmes: cotton, easy care • Special programmes: cotton, shirts, Cotton Eco, lingerie, towels, pillows, mixed fabrics, outdoor, rapid 40, blankets, easy-care, wool drying in basket, timed programme warm <p>Key features</p> <ul style="list-style-type: none"> • Anti crease cycle 120 min at the end of the programme • Fully electronic control dial for sensor and timed programmes • Half Load option: optimises drying for smaller loads • Sensitive drying: large softDry stainless steel drum system and revolution drying system • AntiVibration design: for greater stability and quietness <p>Additional features</p> <ul style="list-style-type: none"> • Large LED display for remaining time and 24 hours time delay, programme progress indication and special functions • NewValue door with cover glass, Alu-Look, white • Speed • Load recommendation • soft dial • Heat pump technology with climate friendly cooling agent • Drum interior light • Container for condensed water • Wool drying basket • Door hinge: right-hand • Metal door catch • Child Lock • End of cycle buzzer <p>Technical Information</p> <ul style="list-style-type: none"> • Slide-under installation • Dimensions (H x W): 84.2 cm x 59.8 cm • Appliance depth: 61.3 cm • Appliance depth incl. door: 64.8 cm • Appliance depth with open door: 109.6 cm <p>¹ At a range of energy efficiency classes from A+++ to D</p>	<p>² Energy consumption kWh per year, based on 160 drying cycles of the standard cotton programme at full and partial load, and the consumption of the low power modes</p> <p>³ Programme time of the standard cotton programme at full load</p> <p>⁴ On a condensation efficiency class scale from A to G</p> <p>⁵ Weighted condensation efficiency for the standard cotton programme at full and partial load</p>

IQ500, Heat pump tumble dryer, 9 kg
WQ45G2D9GB

Dimensioned drawings

Measurements in mm

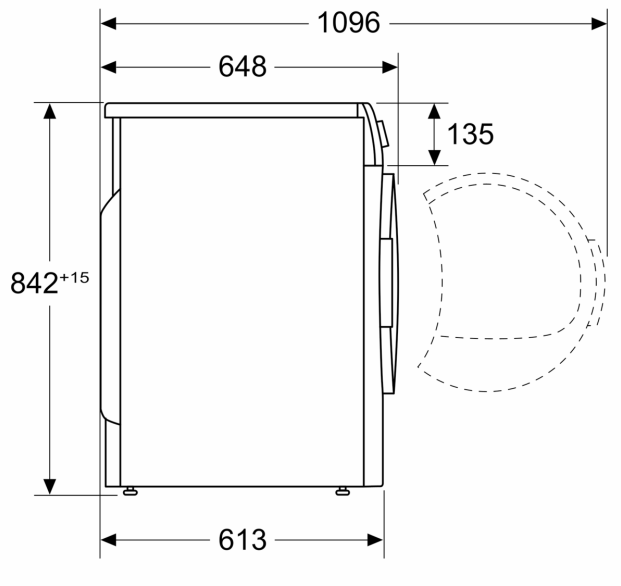

Measurements in mm

